

In-Process Gaging with MicroComp

IN-PROCESS LATHE or OD GRINDING SWING DOWN GAGE.

An operator friendly gaging system for in-process machining or OD grinding. Priced affordably for machine shops. Volume discounts available.

Combines Albion's proven MicroComp gaging amplifier with a "swing down" in-process gage arm. Comes with LVDT. Temperature compensation package is available.

Now you can machine or grind directly to final size. MicroComp will display size while parts are being machined, in real time - instantaneously.

All controls for regular shop floor use are mounted on user-friendly front panel. Clear analog and digital display is easily visible to operator. Mounts easily, wherever convenient.

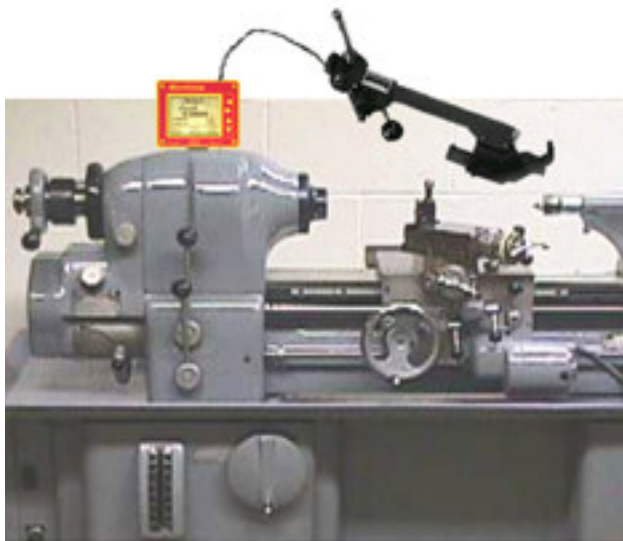

MicroComp mounts on the machine tool and displays LVDT output. Resolution down to sub-micron level.

Easy to use, and inexpensive. The lowest cost high-accuracy, in-process gaging system available

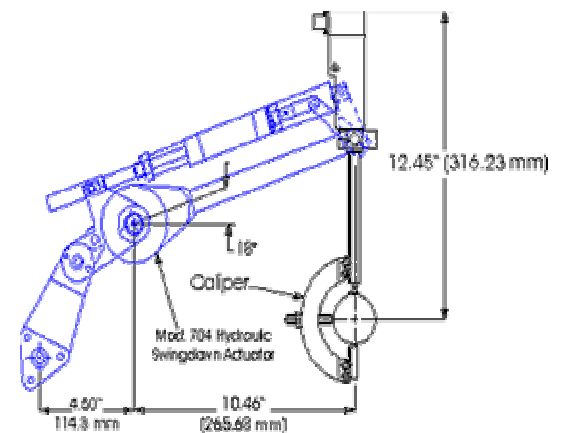

Albion Devices, Inc.
742 Genevieve St., Ste. L
Solana Beach, CA 92075
Tel: 858-792-9585
Fax: 858-792-9644
www.AlbionDevices.com
Email: adi@AlbionDevices.com

Dealer inquiries welcomed.

ALBION DEVICES, INC.