

Sensors for Temperature Compensation applications

Accuracy: 1°F to 140°F (-17°C to 60°C): 0.18°F (.1°C)
 Response: 10°F / 5.5°C change - 2.0 secs, full contact 3.5 secs, line contact
 30°F / 16.5°C change - 2.4 secs, full contact 5.5 secs, line contact

Workpiece/Master Sensors

IS-1 probe. Durable Workpiece/Master sensor usually used on outside measurement applications. 18 month warranty.

Part #: 650301

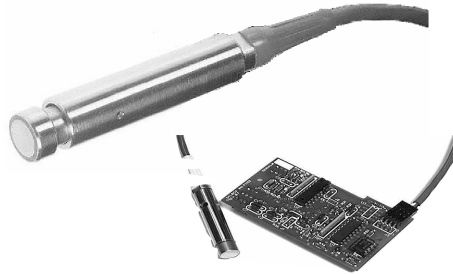

Optional conditioning board, output:
 ±2.5v; ±5v; 0-10v

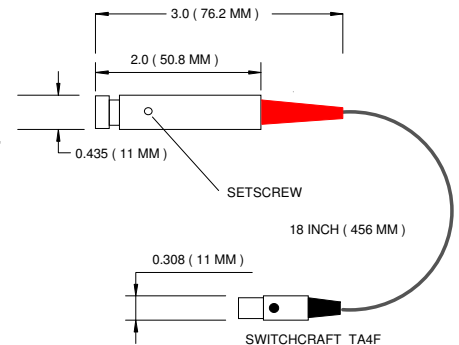

IS-2F (flat face) probe. Durable Workpiece/Master flat faced sensor used where space restricts use of IS-1. 18 month warranty.

Part #: 650394-F

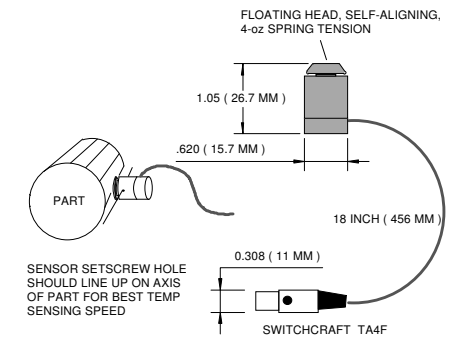

IS-2C (radiused) probe. Durable Workpiece/Master sensor with radiused face, for inside diameter applications. 18 month warranty.

Part #: 650394-C

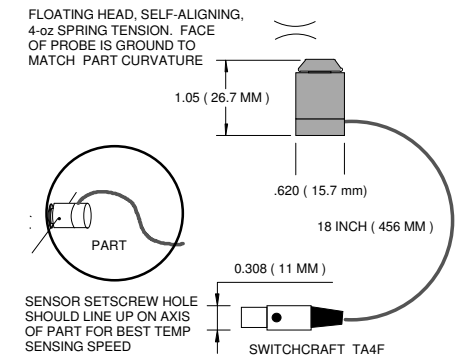



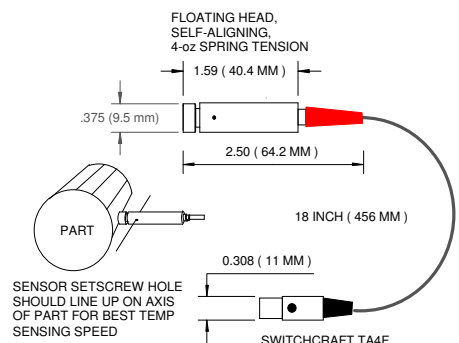

LW-1 probe. Low cost Workpiece/Master sensor 6 month warranty.

Part #: 900112

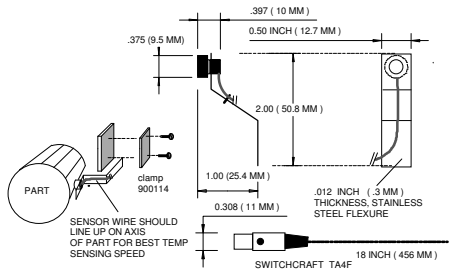

Sensors for Temperature Compensation applications (cont.)

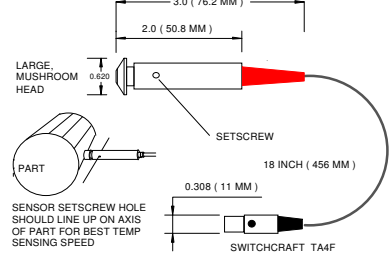
Gage Sensors Workpiece/Master Sensors

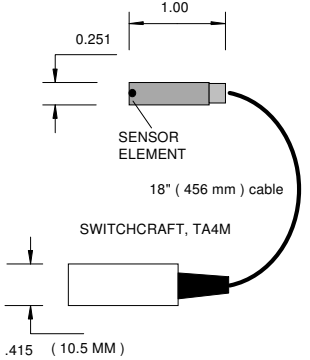
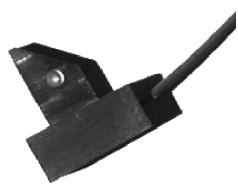
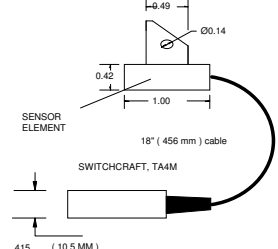
<p>LW-2 probe. Low cost Workpiece/Master sensor on spring flexure. Easily reshaped for access to hard-to-reach locations. 6 month warranty. Part #: 900113</p>		
<p>IS-3 Workpiece/Master sensor with radiused face and 18" cable. 18 month warranty Part #: 650498</p>		
<p>GS-1 Thermistor gage probe for insertion into fixture. Used to sense gage (ambient) temperature. 6 month warranty. Part #: 650302</p>		
<p>LG-1 Thermistor gage probe, for mounting on fixture. 6 month warranty. Part #: 900116</p>		
<p>GS-2 Thermistor needle probe with custom length for deep insertion in gage or gage head. 6 month warranty. Part #: 650327</p>	